

# You'll find real warmth

in the many features of a genuine Fisher stove



Fisher Traditional fires have been warming New Zealand homes for decades. Originally from Canada, the proven design features remain unchanged and will fit any décor.

- Heavy gauge steel construction and fire brick linings for safety and long life.
- Two step top that has been engineered for efficiency and offers the bonus of a multi-level cook top.
- Quick action door latches and single fingertip air control for easy operation.
- Special air flow system that washes unwanted smoke from the glass door and helps prevent soot build-up.
- Ash shelf to catch hot embers.
- Bronze or solid black door options.
- Optional water heating with the multi-fuel models.



## *Blenheim*

- Clean air wood burning fire
- Approximate heating area: 200m<sup>2</sup>
- Emissions: 1.27g/kg
- Efficiency: 71.8%
- CA authorisation #N0022
- 10 year conditional firebox warranty



## *Charleston*

- Multi-fuel fire (wood and coal burning)
- Approximate heating area: 150m<sup>2</sup>
- Removable ash tray
- Optional water heating (up to 5.0kW)
- NES exempt
- 5 year conditional firebox warranty



## *Denniston*

- Multi-fuel fire (wood and coal burning)
- Approximate heating area: 225m<sup>2</sup>
- Removable ash tray
- Optional water heating (up to 5.6kW)
- NES exempt
- 5 year conditional firebox warranty

MINIMUM SPECIFICATIONS (mm)

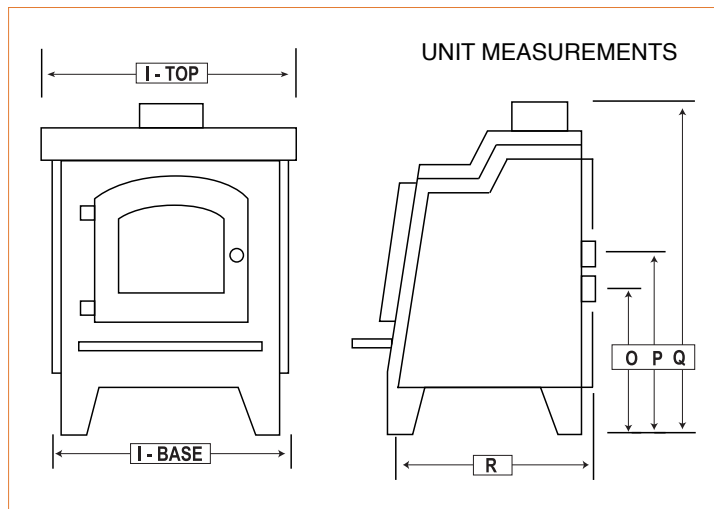
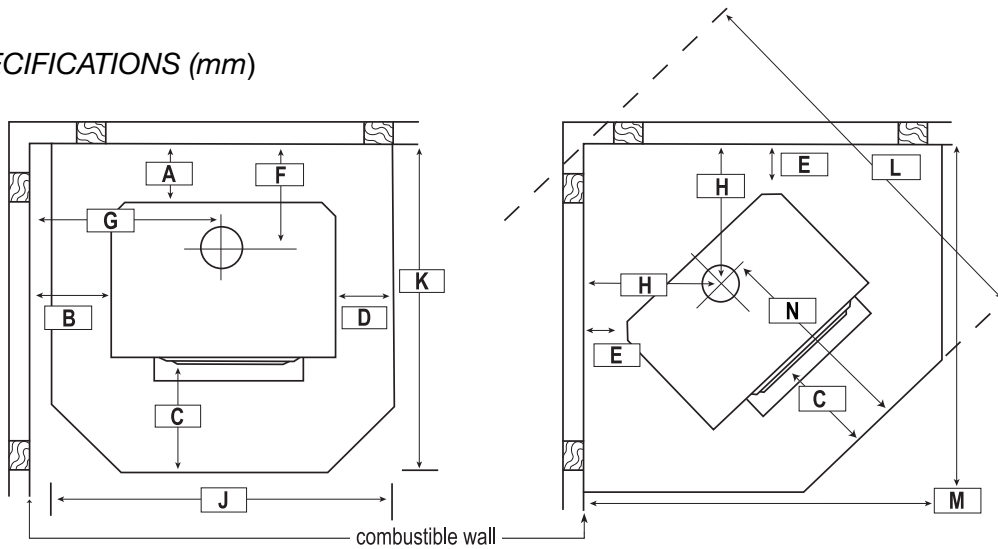

Floor protector requirements: Insulated – Denniston and Blenheim. Non-Insulated – Charleston.

	A	B	C*	D	E	F	G	H	J	K	L	M	N
<b>BLENHEIM – Clean Air</b>													
Fisher Heat Shield & Single S/S Flue Screen	200	350	300	108	150	360	643	451	802	1043	1321	1068	683
<b>CHARLESTON – Multi-fuel</b>													
Fisher Heat Shield & Single S/S Flue Screen	360	450	300	138	250	550	705	545	786	1233	1455	1161	683
<b>DENNISTON – Multi-fuel</b>													
Fisher Heat Shield & Single S/S Flue Screen	220	470	300	107	250	379	763	544	800	1064	1453	1162	685

\* Dimension 'C' is taken from firebox door seal lip to the front of the floor protector

	APPROXIMATE* HEATING AREA	MAX LOG LENGTH	WATER HEATING OPTION	FLUE SIZE	UNIT MEASUREMENTS (mm)								
					I (top)	I (base)	O	P	Q	R			
BLENHEIM CA	200m <sup>2</sup>	460	N/A	150	586	563	N/A	N/A	762	543			
CHARLESTON	150m <sup>2</sup>	410	YES	150	510	498	494	524	733	573			
DENNISTON	225m <sup>2</sup>	460	YES	150	586	563	496	516	794	544			

\*Heating capacities depend on a number of factors. Please consult your heating specialist as to which is right for your home. Specifications or designs may change without prior notice.

Your Fisher stockist:

