

Dimension 'C' is taken from door seal lip (fire box) to the front of the floor protector.  
All dimensions are in millimetres.  
All dimensions are set as a minimum guide only.

Minimum clearance requirements to combustibles with a Fisher heat shield & 1200mm s/s single skin flue screen.

A	B	C	D	E	F	G	H	J	K	L	M	N
360	450	300	138	250	550	705	545	786	1233	1455	1161	683

### Unit Measurements (mm)

(TOP) I	(BASE) I	O	P	Q	R
510	498	494	524	733	573

Approximate Heating Area	Max Log Length	Water Heating Option	Floor Protector
150m <sup>2</sup>	410	Yes	Non-Insulated

IF INSTALLED IN ACCORDANCE WITH THESE SPECIFICATIONS THE HEATER COMPLIES WITH AS/NZS 2918:2001 including Appendix F. The minimum clearance to combustibles may be reduced if the combustibles are shielded with an approved non-combustible material. Details of suitable shielding materials and appropriate clearance reduction factors are present in Section 3 of AS/NZS 2918:2001

## FREESTANDING SPECIFICATIONS

MODEL: MULTI-FUEL

PAGE 2 OF 2

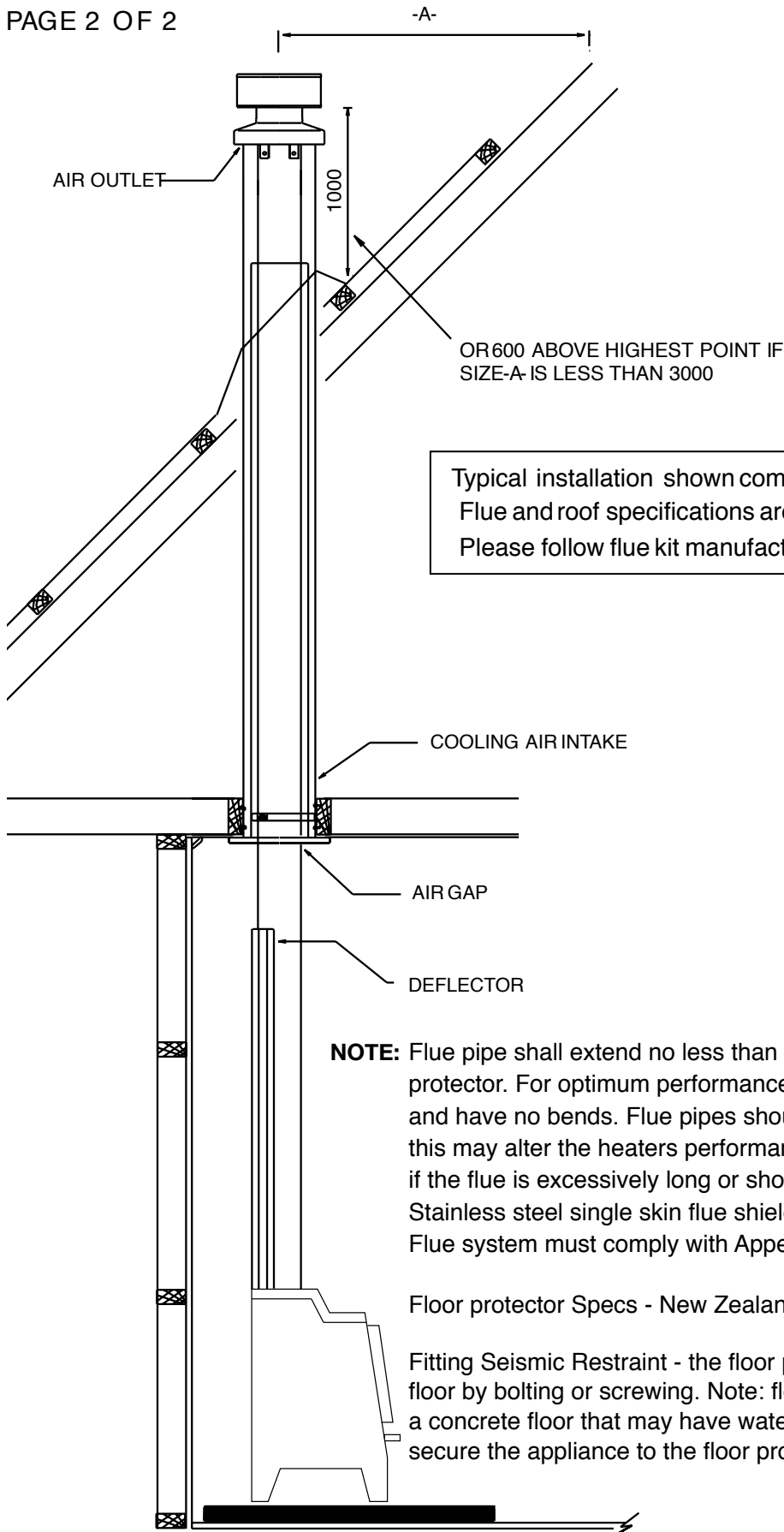

OR 600 ABOVE HIGHEST POINT IF SIZE-A IS LESS THAN 3000

Typical installation shown complies with AS/NZS 2918:2001  
 Flue and roof specifications are recommendations only.  
 Please follow flue kit manufacturers installation instructions.

**NOTE:** Flue pipe shall extend no less than 4600mm above the top of the floor protector. For optimum performance the flue system should be vertical and have no bends. Flue pipes should be Ø150mm (Ø6"). Deviation from this may alter the heaters performance and may nullify the Fisher warranty if the flue is excessively long or short, if in doubt contact your Fisher supplier. Stainless steel single skin flue shield tested on this unit. Flue system must comply with Appendix F of AS/NZS 2918:2001.

Floor protector Specs - New Zealand minimum non insulated floor protector only.

Fitting Seismic Restraint - the floor protector must be mechanically fixed to the floor by bolting or screwing. Note: floor protector to be fixed by gluing when on a concrete floor that may have water pipes or electrical wires present. Drill to secure the appliance to the floor protector using two 6mm x 50mm dynabolts.