



BLENHEIM FS CA

SOLID FUEL HEATER
INSTALLATION & OPERATING INSTRUCTIONS

***Congratulations on the purchase of your Fisher wood heater.
Please read this installation and operation manual carefully.
The installation of this fire must comply with the Installation Standard
AS/NZS 2918 as well as any additional local requirements.
Please ensure you have all relevant permits prior to installation.***

Keep this booklet as a reference guide.

Installation of Fisher Wood Heater

Fisher recommends you use a qualified solid fuel heater installer or a registered plumber to install your fire. Your dealer or heating specialist will be able to help with recommendations as well as advise on permits/consents required for the installation in your area.

Please follow carefully all dimensions and recommendations provided on the individual specification sheet for your model of heater as these dimensions comply with the required New Zealand standard (AS/NZS 2918:2001).

As safety and emissions performance can be affected by altering the appliance, no modifications are allowed without the written permission from the manufacturer.

INSTALLATION

- 1 Unpack the heater and check that there is no damage.
- 2 Ascertain the position of the roof penetration for the flue system. A correctly installed flue system will normally prevent down draught problems during windy weather and eliminate smoke spillage problems due to lack of draught.
- 3 Ascertain suitable position for appliance and size of floor protector and check the ceiling to ensure that no major structural members will be affected by the path of the flue.
- 4 Check that the sub-structure is capable of carrying the heater (i.e. weight consideration on the floor).
- 5 Check measurements of the heater to combustibles or shield.
- 6 Locate the heater in the required position (also see 'Fitting Seismic Restraint' after installation instruction #10).
- 7 Using a plumb line fastened to the ceiling, mark the centre of the flue penetration position and cut the ceiling hole to the required size and frame out.

- 8 Install the flue system (see flue installation instructions supplied with flue system).

Remember:

- The flue system should rise vertically from the appliance with as few offsets as possible. Offsets should be avoided where possible as each change in direction creates a resistance to airflow and makes flue cleaning difficult.
- The flue system must be well sealed with a minimum of 3 fixings at each joint.
- The flue pipe penetrating the chimney must continue to the minimum length of 4.6m from the top of the floor protector to the cowl.
- Flue exiting more than 3 metres from the ridgeline must terminate no less than 1 metre above the roof penetration (see diagram 1 below).
- Where the top of the flue pipe is more than 2 metres above its highest fixing point, it must be stayed against high winds.

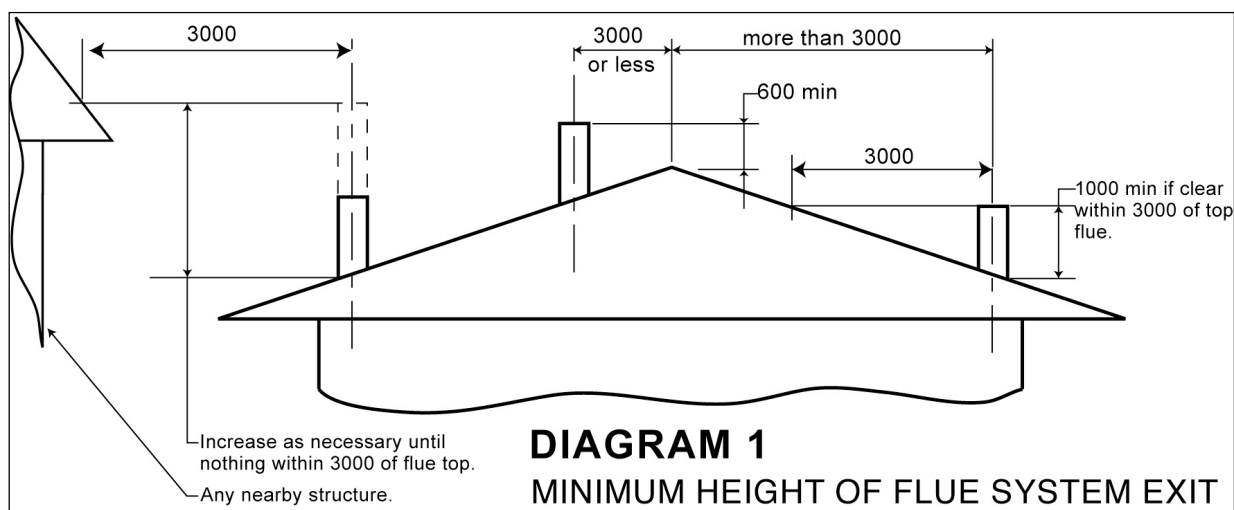

- 9 Drill and fix flue system into flue spigot with stainless steel self-tapping screws.
- 10 Drill and secure the appliance to the floor protector using the two holes in the rear legs of the appliance.

FITTING SEISMIC RESTRAINT

The Floor Protector must be mechanically fixed to the floor by bolting or screwing. **Note:** Floor Protector to be fixed by gluing when on a concrete floor that may have water pipes or electrical wires present. The appliance can then be bolted to the floor protector with two 6mm x 50mm dynabolts.

BAFFLE

Before lighting your appliance for the first time, make sure the baffle is in the correct position being as far to the rear as possible.

Warnings

- 1. WARNING: THE HEATER AND FLUE SYSTEM SHALL BE INSTALLED IN ACCORDANCE WITH AS/NZS 2918 AND THE APPROPRIATE REQUIREMENTS OF THE RELEVANT BUILDING CODE OR CODES.**
- 2. WARNING: APPLIANCES INSTALLED IN ACCORDANCE WITH THIS STANDARD SHALL COMPLY WITH THE REQUIREMENTS OF AS/NZS 4013 WHERE REQUIRED BY THE REGULATORY AUTHORITY, i.e. THE APPLIANCE SHALL BE IDENTIFIABLE BY A COMPLIANCE PLATE WITH THE MARKING 'TESTED TO AS/NZS 4013'. ANY MODIFICATION OF THE HEATER THAT HAS NOT BEEN APPROVED IN WRITING BY THE TESTING AUTHORITY IS CONSIDERED TO BE IN BREACH OF THE APPROVAL GRANTED FOR COMPLIANCE WITH AN/NZS 4013.**
- 3. PLEASE ENSURE THAT ONLY COMPONENTS APPROVED BY FISHER ARE USED FOR THE INSTALLATION as substitutes may adversely affect performance and might nullify compliance with the requirements of AS/NZS 2918. CAUTION: MIXING OF HEATER OR FLUE SYSTEM COMPONENTS FROM DIFFERENT SOURCES OR MODIFYING THE DIMENSIONAL SPECIFICATION OF COMPONENTS MAY RESULT IN HAZARDOUS CONDITIONS. WHERE SUCH ACTION IS CONSIDERED, THE MANUFACTURER SHOULD BE CONSULTED IN THE FIRST INSTANCE.**
- 4. CAUTION: CRACKED AND BROKEN COMPONENTS, e.g. GLASS PANELS OR CERAMIC BRICKS MAY RENDER THE INSTALLATION UNSAFE.**

Any variation from these installation instructions or any doubts about them must be checked against the requirements of the AS/NZS 2918.

Correct Operation of Your Fisher Solid Fuel Heater

Simply by burning your Fisher heater correctly, you can improve efficiency, reduce fuel consumption and minimise air pollution.

STARTING A NEW FIRE

Please note: If lighting the heater for the first time dust heater, glass, trim and flue before firing to avoid particles sticking or discolouring. Once fired, some smoke and vapour will be released as the VHT painted surfaces enter the final curing process. Open all windows and doors while running the fire on high for up to 3 hours. People with respiratory, heart or other relevant medical conditions should avoid inhaling vapours during the curing process. All VHT paint will cure at the highest temperature achieved and will produce smoke again if this temperature is exceeded.

To start and maintain a good fire you will need the following ingredients:

1. A small quantity of newspaper (do not use coloured or coated paper);
2. A packet of firelighters (optional)
3. A quantity of finely split, dry soft wood kindling in a variety of sizes; and
4. Seasoned firewood split into a range of piece sizes.

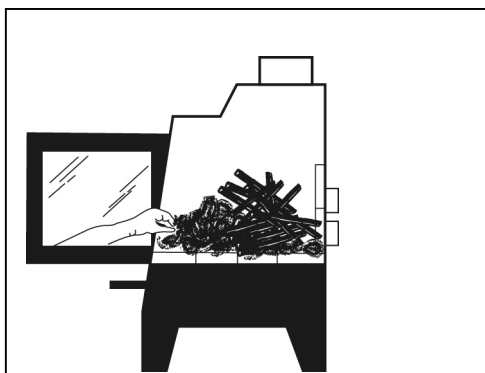

TO BUILD A QUICK, HOT FIRE

Use plenty of crumpled newspaper and dry, finely-split kindling. Set the air control fully open. Light the newspaper near where the combustion air enters the firebox. When a kindling fire is built properly, you should expect fast ignition and no smouldering.

The first step is to crumple half a dozen sheets of newspaper and put them just inside the firebox. The amount of newspaper you need will depend on the firebox size, and the dryness and fineness of the kindling you are using. The drier and finer the kindling, the less newspaper you need. Many people make the mistake of using too little newspaper. Be generous with the newspaper and you will have more success. Putting some firelighter halves under the newspaper can also help sustain firebox temperature until the wood is burning.

On top of the paper place 10 to 15 pieces of finely split, dry kindling. Softwoods, such as cedar or pine, make good kindling. Ideally, the kindling should be placed on the newspaper so that the combustion air reaches the newspaper fast where you ignite it. It is also a good idea to add two or three very small pieces of firewood to the kindling load before lighting.

Set the air control to fully open, light the firelighters or the newspaper and close but do not latch the door. After about 5-10 minutes, when the wood is flaming brightly, latch the door (some longer flue installations may require door to be left unlatched for up to 15 minutes until the flue system is warm and producing strong draught). Since leaving the door open slightly can cause dangerously high temperatures, never leave the woodstove unattended while starting the fire.

When the flames from the kindling load just begin to subside, add several **small** pieces of firewood. Try to avoid smothering the fire with the new pieces. Placing the pieces on the burning kindling can help prevent smothering. As your Fisher heater is a radiant heater it requires approximately 45-60 minutes to preheat the steel firebox before it can effectively radiate heat into the room. **Place firewood in a uniform position, front to rear loading.** A well maintained, hot fire will reduce the preheat cycle.

REKINDLING A FIRE FROM CHARCOAL OR EMBERS

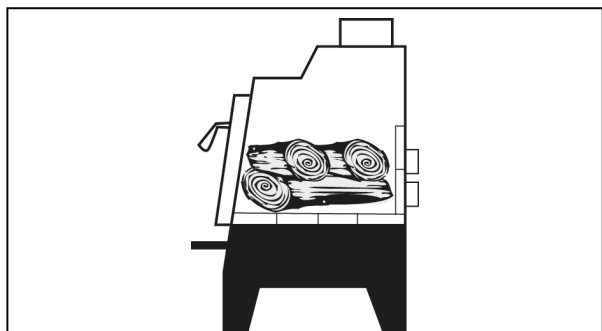

TO REKINDLE A FIRE FROM HOT COALS:

Spread the charcoal evenly throughout the firebox. Place small pieces of wood on and behind the coals. Open the air inlets fully and leave them open until the pieces of wood are well charred. This illustration shows the arrangement of pieces for an

Embers found at the back of the firebox should be raked evenly around the fire. If only a small amount of embers remain, you will have to start with kindling. If there is a good quantity of glowing embers to work with, place at least three, and preferably more than five pieces of small firewood on the embers. Open the air inlets fully and close the door.

If everything is just right, fast ignition of the new load should be expected. Allow the fire to burn with bright turbulent flames until the wood is completely alight. This usually takes between 15 and 30 minutes, depending on the size of the pieces and the moisture content

of the wood. When the wood is burning well, reduce the air setting to produce the amount of heat and length of burn desired. Reducing the air control setting in two or three stages will result in less air pollution because the fire will not have to recover from the single, large reduction in air supply.

The most important rule is **NEVER LET THE FIRE SMOULDER**. As long as there is solid wood in the firebox, there must be flames present or the unburned gases will escape, both reducing efficiency and increasing air pollution.

Always open the fire door slowly to allow fresh air to enter and maintain the smoke path. If you open the door too quickly, smoke can puff out.

SOME OTHER USEFUL TIPS

Fuel load geometry: Small pieces of firewood arranged loosely in a crisscross pattern burn quickly because the combustion air can reach all the pieces at once. Larger pieces placed a little more compactly burn slower. Once your heater has reached maximum temperature, it is more efficient to top up frequently with about 25% of a full load rather than let the fire die down and need to completely refill it.

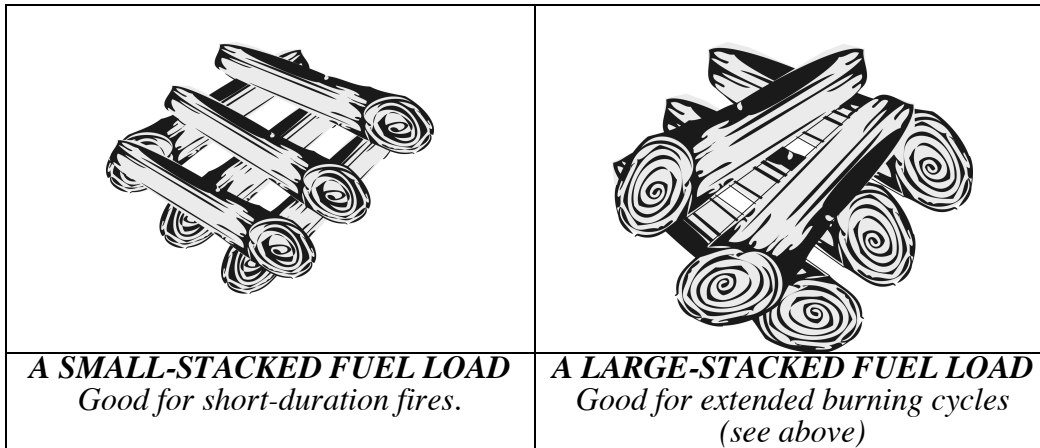

Small and Large Fuel Load Geometry

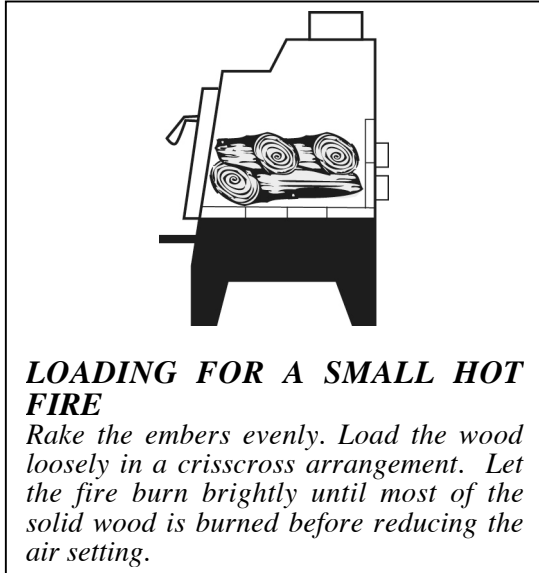

Fire in cycles: Don't expect perfectly steady heat output from your Fisher heater. Solid fuel heaters burn in cycles. A cycle is the time between the ignition of a load from charcoal and the consumption of the load back to a coal bed. Plan the firing cycles around your household routine. If someone is home to operate the heater, build a small hot fire. If you must be away from the house during the day, build a long-burning fire.

The small, hot fire: A small, hot fire is a small amount of wood burned quickly. Use it when you just want to take the chill off the house. The small hot fire technique eliminates the smouldering fires that are

common when people don't need their heater running hot all the time, like in spring and autumn. To build a small hot fire, rake the embers evenly in the firebox and place several small pieces of firewood on it. The bottom layer should be placed to ensure that combustion air can flow over the embers and along the length of the pieces of wood. The next layer should be stacked loosely in a crisscross arrangement. Open the air inlet to produce a hot, bright fire. After approximately 15–20 minutes the air supply can be reduced slightly as the fire progresses, but never enough to extinguish the flames. When only charcoal remains, the air supply can be reduced further to prevent cooling the ember bed. Reload with small pieces often, as full loads will smother the ember bed.

The long-burning fire: To achieve a long burning fire, rake the embers evenly, as with the small hot fire, and use larger and more pieces of wood. Place the pieces in a similar pattern to the small hot fire, using more pieces and larger pieces (especially the top layer). **Always make certain that there is a gap between the pieces to ensure that the combustion air can reach all pieces.** Open the air inlets fully for between 15 to 30 minutes depending on load size and fuel moisture content. When the fire is burning fiercely (at least 15 minutes), reduce the air control in stages to the desired level. This allows you to turn down the air control and still maintain a clean-burning fire.

REMEMBER: NEVER LET THE FIRE SMOULDER.

Preventing creosote build-up: Creosote is a tar-like substance that builds up when the organic compounds in smoke condense onto cooler flue surfaces. Left to build up over time, creosote will restrict the airflow of the flue and impair the performance of your heater. The production of smoke is at its highest when a fresh fuel load is added or when the air control is at its lowest position. The most effective way to control the creosote formation is to burn the heater so as to ensure as complete combustion as possible and at the same time promoting higher flue temperatures. Smoldering fires should always be avoided.

The amount of charcoal in the ash is often a good indicator of how well you are operating the heater. If there is no charcoal and only very fine ash, then you are doing an excellent job. If there is a lot of charcoal you may be turning the combustion air down too soon after re-fuelling, or not raking the charcoal to the combustion air inlet, or turning the combustion air down too low to support efficient combustion, or all of the above.

REMEMBER: THE HOTTER THE FIRE, THE LESS CREOSOTE FORMATION.

When you have mastered the techniques for efficient wood burning, here is what you should see:

1. When wood burns it should be flaming until only charcoal remains. If there are no flames, something is wrong.
2. Firebricks in the firebox should be tan in colour, never black.
3. Steel parts in the firebox should be light to dark brown, never black and shiny.
4. With seasoned wood, correct air settings and proper loading arrangement you should expect quick ignition of a new load of wood - the bottom pieces should be flaming by the time the door is closed.
5. The glass door should be clear. A discoloured glass indicates that the wood is too wet or the air control has not been left open long enough.
6. The exhaust coming from the top of the flue system should be clear or white. A plume of blue or grey smoke indicates smoldering, inefficient combustion, air pollution and probably low operating temperatures.

Correctly installed and operated, Fisher solid fuel heaters do not spill smoke into the house. There are three main reasons why some woodstoves smoke:

Bad installation design: Incorrect flue installation, resulting in low flue temperatures and low draught, can make a wood heater more likely to spill smoke. For example, flue systems that run up the outside wall of the house and are not correctly insulated can rob the heat from the flue and produce very little draught. Each elbow in the flue pipe assembly slows down the flow of gases and causes a small restriction to flow. When a flue system includes more than one elbow, the restriction can be enough to cause spillage.

Extreme negative pressure in the house: Energy efficiency practices and new building code rules are making our houses more and more airtight. This makes the houses energy efficient, but also makes them more sensitive to negative pressure when air is exhausted from the house. Large, fan-forced exhaust ventilators, like down-draught-type kitchen stove exhausts, can cause extreme negative pressure in the house when they are operating. Because new houses are tightly sealed, there are few holes to allow replacement air to enter, and the house pressure becomes negative. This negative pressure works against flue system draught. In severe cases, the negative pressure in the house overcomes the flue system draught and the appliance begins to spill smoke, especially when a fire is started or when it dies down to coals. To prevent this extreme negative pressure, one option is to open a window slightly to allow combustion air into the room.

Improper heater firing technique: When a solid fuel heater is starved for air it smoulders, producing a relatively cool, smoky fire. The temperatures throughout the system are low. During a smouldering fire, the flue system will not be receiving the hot gas it needs to produce strong draught. When the heater door is opened, smoke will spill into the room. A smouldering fire is the single most common reason for smoke spillage and totally unnecessary. By using the suggestions on proper firing technique earlier in this document, you will be able to avoid these smouldering fires.

PURCHASING THE FIREWOOD

The quality of the firewood you burn can have a dramatic effect on the efficiency and operation of the heater. The main factors that affect the burning characteristics of firewood are moisture content, tree species and piece size.

The moisture content of the wood affects the rate at which it burns and the efficiency of combustion. When trees are cut, the wood moisture content ranges between 35 and 60 percent by weight. If you attempt to burn wood this wet it will be hard to ignite, slow to burn and will hiss and sizzle in the firebox. So much energy will be consumed in boiling off the excess water that the efficiency of combustion and the heat to your home will be low, condensation and corrosion may be occurring in the flue and smoke may be causing problems to your neighbours. Properly seasoned wood ignites readily and burns efficiently.

PLEASE NOTE: WOOD WITH A MOISTURE CONTENT OF 25% OR LESS IS THE ONLY APPROVED WOOD TO USE IN CLEAN AIR ZONES

Firewood should be cut and split in the early spring and stacked under cover, with good ventilation, to be ready for burning when required.

Look for checks or cracks in the end grain as a sign of dry wood. The stacks of firewood should be in an open area so that air can circulate through them. During the summer, as warm breezes flow through the stacks, carrying away the evaporating water, the moisture content of the wood will fall to around 20 per cent. At this moisture content the wood is ready for burning.

Although the energy content of dry wood per kilogram is almost the same regardless of species, softwoods and hardwoods burn differently because of differences in density. Softwoods, such as pine, are less dense than hardwoods like gums, Manuka or Black Wattle. A denser wood will produce a longer-lasting coal bed, while a less dense wood will bring a fire to an optimum burning temperature more quickly.

The size of the firewood pieces affects the rate of combustion. Larger pieces ignite and release their energy more slowly than small pieces. Smaller pieces are better for short, hot fires and larger pieces are preferable for extended firing cycles. In general, commercial firewood dealers supply firewood in thicker pieces than modern wood-burning heaters can handle. It is often necessary to split some of the wood again before using it. The thickest piece size for high-efficiency heaters should not exceed about 150 mm (6 in.) across the largest dimension and a range of smaller pieces will be needed for effective stoking. Maximum log length varies according to model.

BURNING COAL

Due to their construction, the burning of coal in the Fisher Blenheim Clean Air heater is prohibited. Please also refer to 'Exclusions' in the Warranty Page 14.

Fisher Solid Fuel Heater Maintenance

To keep your heater burning clean and efficient it is important that you carry out regular maintenance. General maintenance checks should include the following:-

ASH REMOVAL - Due to the high efficiency of your Fisher heater, ash removal should only be necessary every few weeks. Ashes can be removed easily through the fire door when the fire is at its lowest, such as first thing in the morning, or when it is completely out. Always use a metal container for ash removal as ash can maintain high temperatures for several days. Fisher heaters work best when a small amount of ash (approximately 20mm deep) is left in the firebox after cleaning. This insulates the bottom and prevents the base of the stove overheating and burning out. In fact, building up the ash bed helps extend the long burn cycle, while reducing the ash bed encourages greater heat output.

SURFACES - Fisher solid fuel heaters have high temperature paint surfaces which just need wiping to clean when the fire is cold.

FIREBOX - Check the firebricks, top baffle, air tube and interior surfaces. These parts are subjected to considerably high temperatures and stress and some parts will eventually need replacing.

DOORS - Check all gaskets used for wear and replace if necessary. Adjust door fitting if required.

LUBRICATION - All moving parts should be lubricated with graphite grease every couple of months.

CHIMNEY CLEANING AND CHECKING FLUES

For all wood heaters, flue cleaning must be done regularly to avoid serious flue fires. Frequently used heaters should be cleaned at least once a year (some sooner). The cleaning rate, however, depends on the burning habits of the individual operating the wood heater. For example, it is possible to clog a flue in just a few weeks if smouldering fires are burnt and the flue is run cold.

It is recommended that flue sweeping be done by a professional chimney sweep. Chimney sweeping is a specialist task and competent professional sweeps are available throughout the country. When the flue is cleaned it is recommended that other parts, such as baffles, are checked.

Flue systems should be checked at least once or twice a heating season. Flue systems may require checking more often if the fuel or operation of the appliance is incorrect. When a flue system becomes excessively blocked or requires frequent cleaning, advice should be sought to investigate the installation and the operation of the heater. Flue pipes can deteriorate very quickly with incorrect firing.

Warnings

Below is a list of warnings to ensure efficient and safe operation of your Fisher heater:

- **WARNING: DO NOT USE FLAMMABLE LIQUIDS OR AEROSOLS TO START OR REKINDLE THE FIRE.**
- **WARNING: DO NOT USE FLAMMABLE LIQUIDS OR AEROSOLS IN THE VICINITY OF THIS APPLIANCE WHEN IT IS OPERATING.**
- **WARNING: DO NOT STORE FUEL WITHIN HEATER INSTALLATION CLEARANCES.**
- **WARNING: OPEN AIR CONTROL BEFORE OPENING FIRING DOOR.**
- **CAUTION: THIS APPLIANCE SHOULD NOT BE OPERATED WITH A CRACKED GLASS.**
- **CAUTION: THIS APPLIANCE SHOULD BE MAINTAINED AND OPERATED AT ALL TIMES IN ACCORDANCE WITH THESE INSTRUCTIONS.**
- **CAUTION: THE USE OF SOME TYPES OF PRESERVATIVE-TREATED WOOD OR DRIFTWOOD AS A FUEL CAN BE HAZARDOUS.**

FISHER FIRE WARRANTY

THIS IS AN IMPORTANT DOCUMENT - KEEP IT IN A SAFE PLACE

CONGRATULATIONS!

We appreciate your decision to invest in our product. Your heater will become an integral part of your lifestyle, heating your home during the colder months and at the same time maintaining its appearance as a quality appliance. We want you to get the best possible performance from your fire and for this reason ask that you read this booklet carefully to take full advantage of your warranty.

In particular we urge you to have your heater and flue inspected annually and the flue swept if necessary. At the same time any other minor potential problems can be detected and corrected before they turn into major ones.

We think this is a small price to pay to ensure your heater is kept in peak condition. There is no doubt in our minds that you will extend the life of your heater.

We select only certain companies to act as our Fisher fire dealers as we believe they must have high standards and be able to provide a total service both pre and post sale to you the customer. Therefore we have every confidence that our dealers will be able to answer your questions or fix any problem that may occur. If you have any further queries, please contact us at:

RETAIL LINKS

P O BOX 9056

ANNESBROOK

NELSON

NEW ZEALAND

FAX: 03 5470780

EMAIL: info@retaillinks.co.nz

Thanks again for choosing a Fisher solid fuel heater. We wish you many warm winters to come!

FISHER FIRE SOLID FUEL HEATER WARRANTY 10 YEARS (conditional)

Standard Warranty

This heater is warranted for ten years, with the exception of the following: - door seal, glass, glass seal, firebricks, secondary air systems, and removable baffle which will have a twelve month warranty (parts only), provided it has been installed by a Home Heating Association registered installer, or an installer recognised by the Manufacturer.

Conditions

The heater must be installed in accordance with the manufacturers' instructions and all relevant standards, regulations and by-laws. The company is not liable for any consequential damage by a failure or defect covered by this warranty. All claims against this warranty must be directed first to the retailer of the store. Any repairs undertaken without the written authority of the Manufacturer, will invalidate this warranty.

Fisher Blenheim CA model is not approved to be fitted with a Water Booster.

The warranty is only valid to the initial purchaser of the product.

Exclusions

This warranty does not cover damage caused by:

- ◆ Mishandling, misuse, abuse, alteration.
- ◆ Normal wear and tear.
- ◆ Work done by others such as installers, plumbers or chimney sweeps.
- ◆ The burning of household rubbish, coal, particle board or the like, salt laden driftwood or any chemically treated wood or fuel of any kind.
- ◆ Other products such as flues or non genuine replacement parts.

The warranty does not cover delivery of the defective part to the dealer or its reinstallation following repair or replacement.

The manufacturer is not responsible for site conditions such as draughts, cleaning and servicing.

Procedure

If a defect occurs, contact your dealer and the part will be repaired or replaced at our option.

Transferability

This warranty is non transferable.

It is recommended you have your dealer inspect your heater annually during the warranty period.

FISHER reserves the right to change specifications or design of its product without prior notice.



WARRANTY CARD

PLEASE COMPLETE AND RETURN WITHIN 30 DAYS OF INSTALLATION TO

RETAIL LINKS LTD
PO BOX 9056
ANNESBROOK
NELSON

NAME: _____

ADDRESS: _____

EMAIL: _____ PHONE: _____

FISHER MODEL: _____

SERIAL NUMBER: _____

DATE PURCHASED: _____

PURCHASED FROM: _____

DATE INSTALLED: _____

INSTALLED BY: _____

Retail Links Ltd reserves the right to change specifications or design of its product without prior notice.

www.fisherstoves.co.nz